

Place de la radiothérapie dans la prise en charge post-opératoire des adénomes hypophysaires non fonctionnels

Dr Thomas CHARLEUX

CHU Bordeaux



RADIOTHÉRAPIE - QUOI DE NEUF ?
POST-CONGRÈS 2019

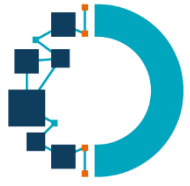

Adénomes Hypophysaires

- Tumeurs bénignes
- Incidence : 3,47 / 100 000 soit > 2000 /an

Adénomes Hypophysaires Non Fonctionnels :

- 1/3 des adénomes hypophysaires
- Diagnostic sur des symptômes compressifs

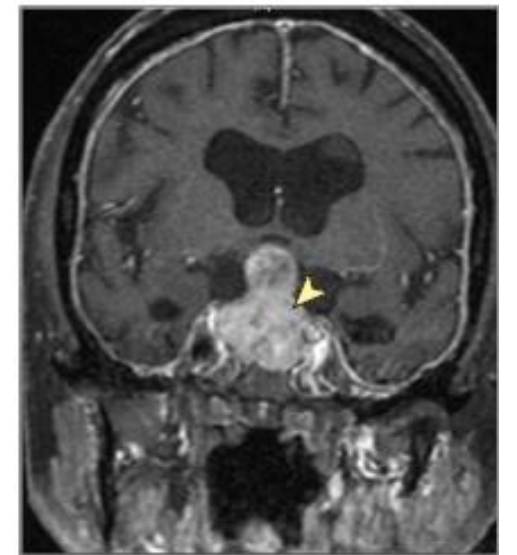

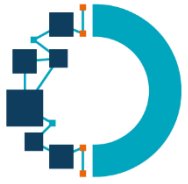

Adénomes Hypophysaires Non Fonctionnels

Taux de rechute

- Chirurgie exclusive :

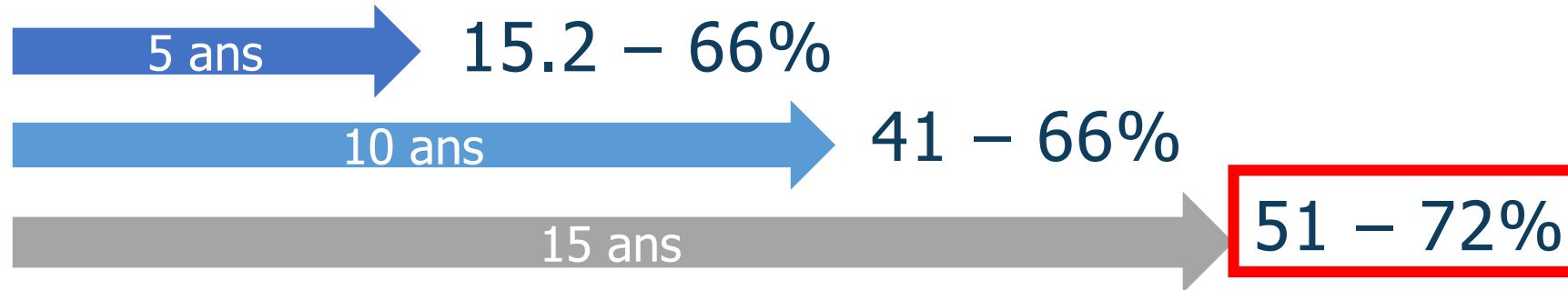

- Radiothérapie :

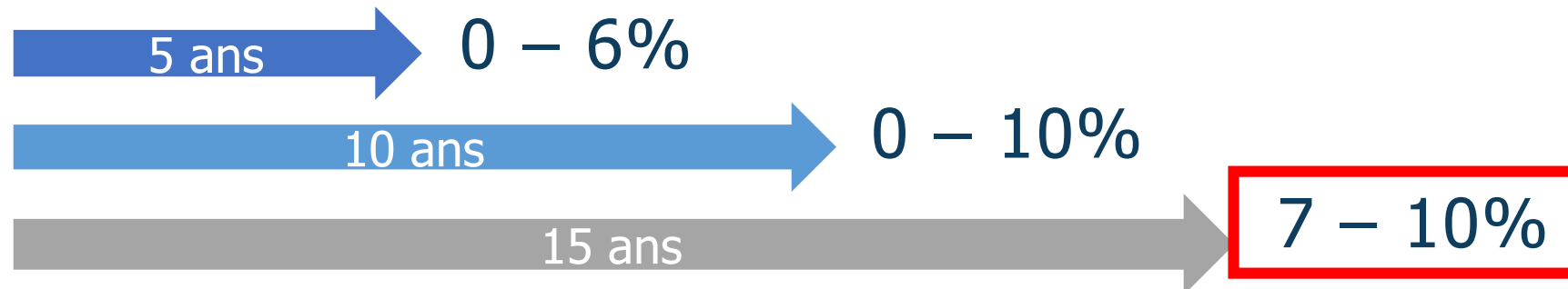

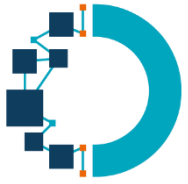

Adénomes Hypophysaires Non Fonctionnels

Taux de rechute

- Chirurgie exclusive :

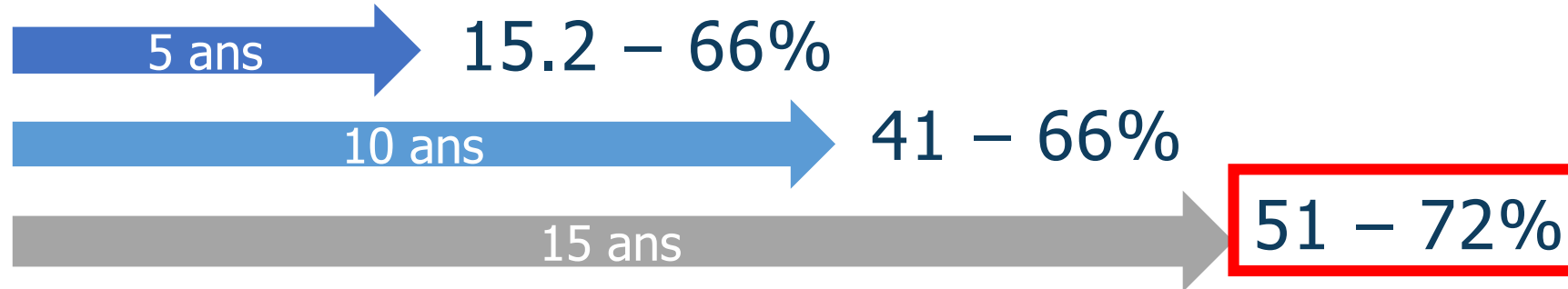

- Radiothérapie :

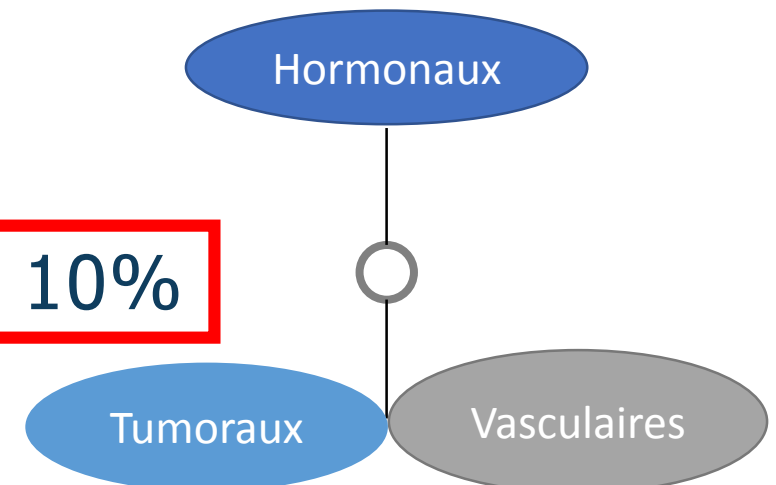
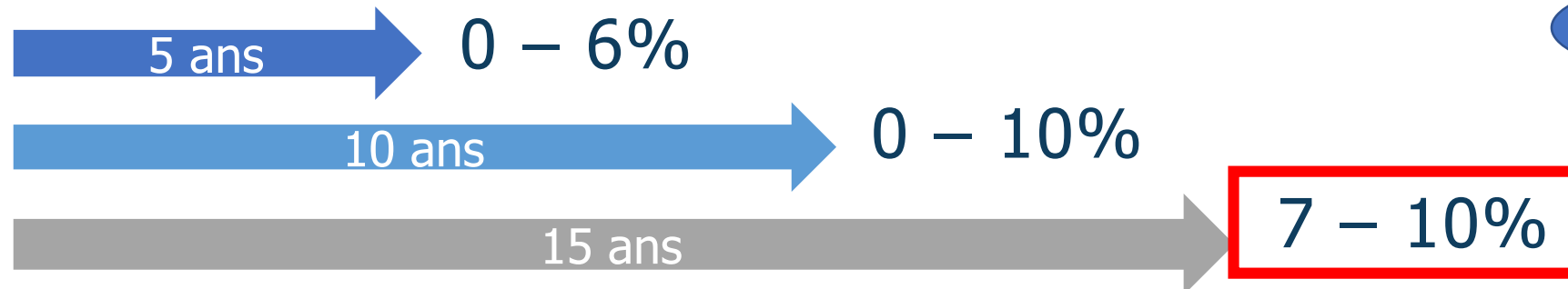

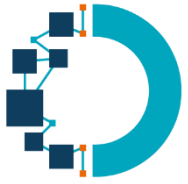

Stratégie

AHNF



Chirurgie



Traitement ?



Surveillance ?

Survie Sans Traitement

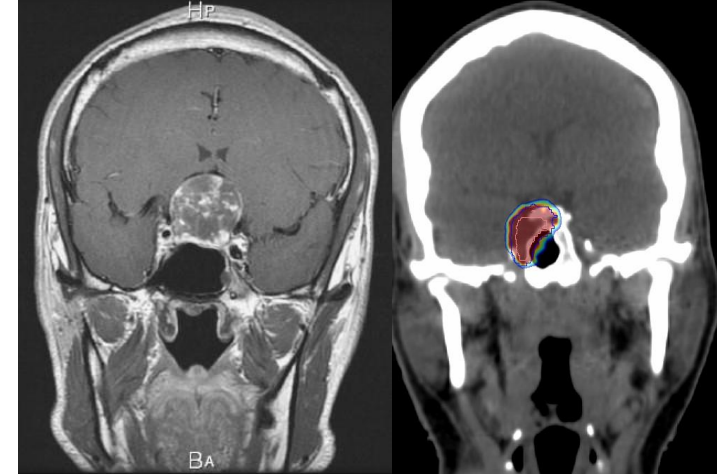

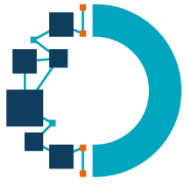

Population et Séquence Thérapeutique

256 patients
Suivi médian 10.2 ans [0.6 – 40.1]

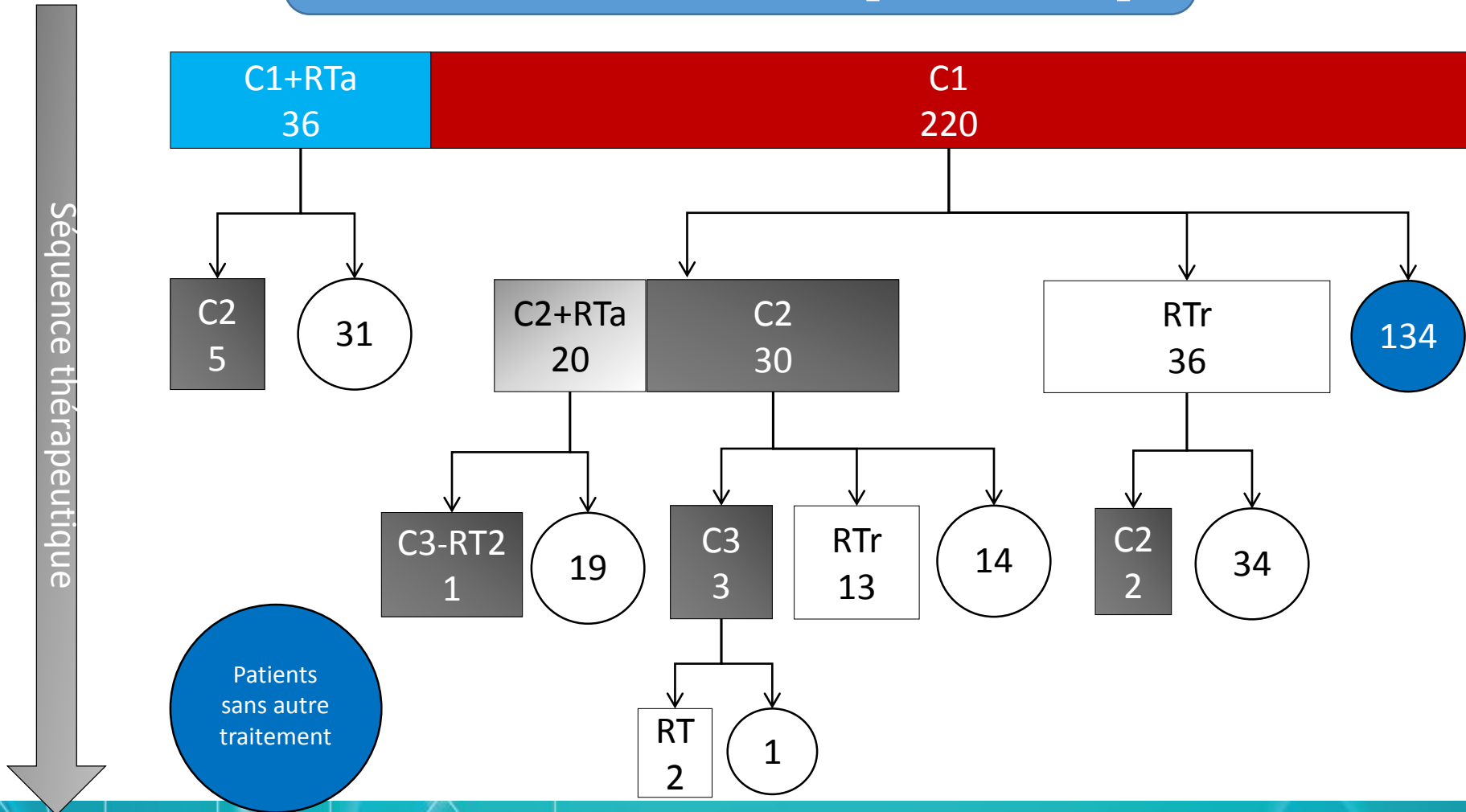

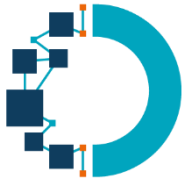

Population et Séquence Thérapeutique

256 patients
Suivi médian 10.2 ans [0.6 – 40.1]

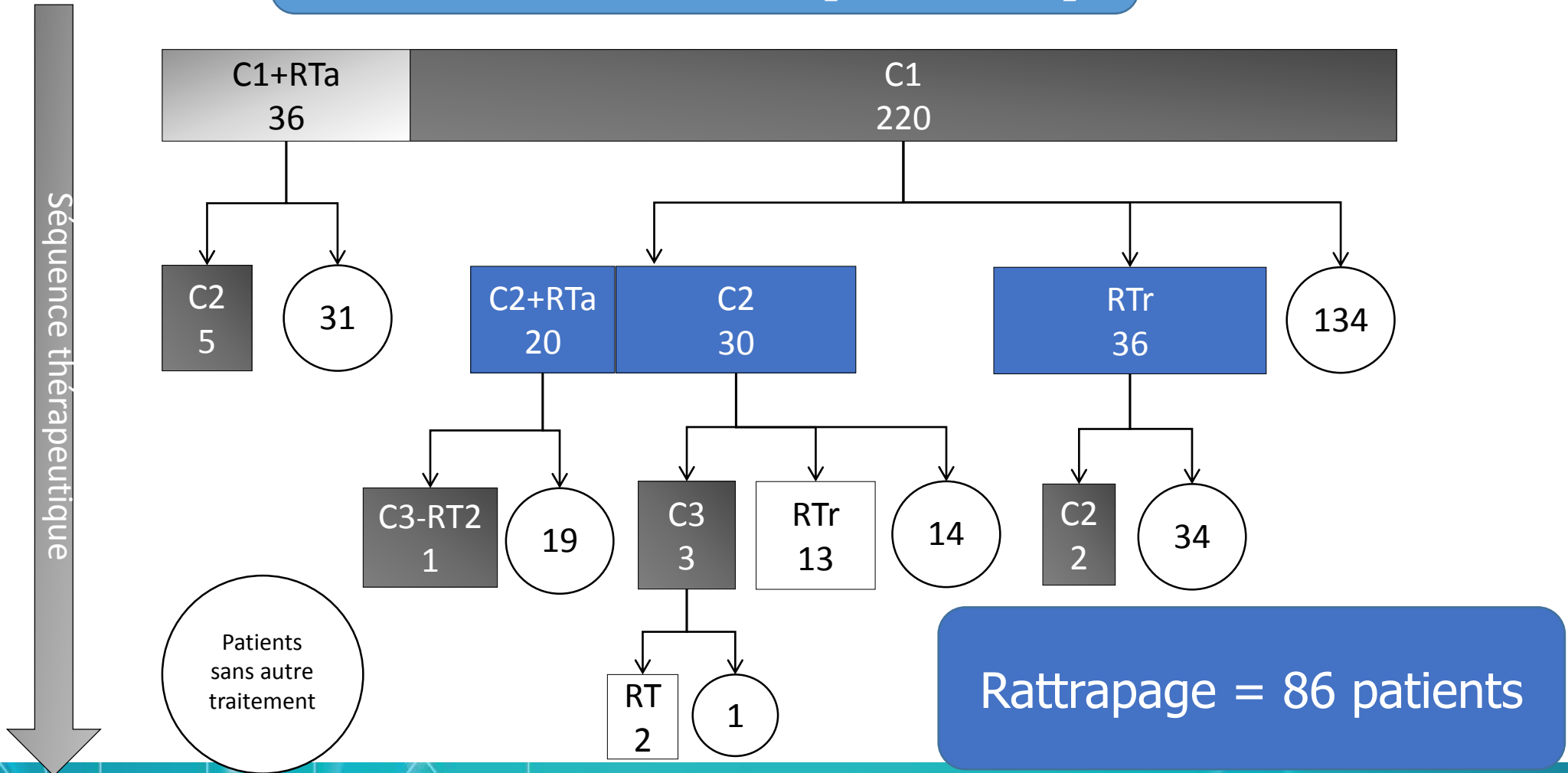



Radiothérapie adjuvante

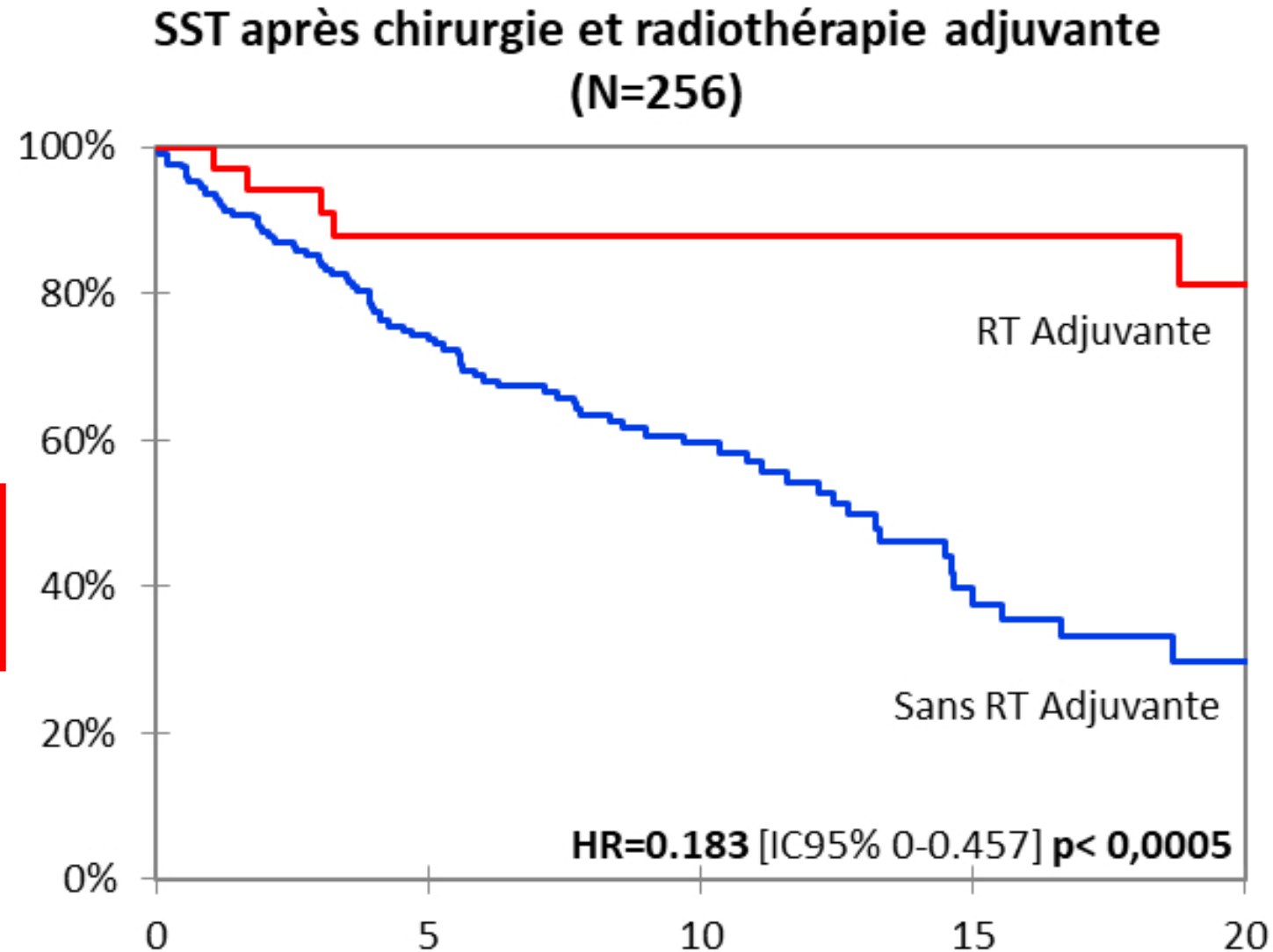
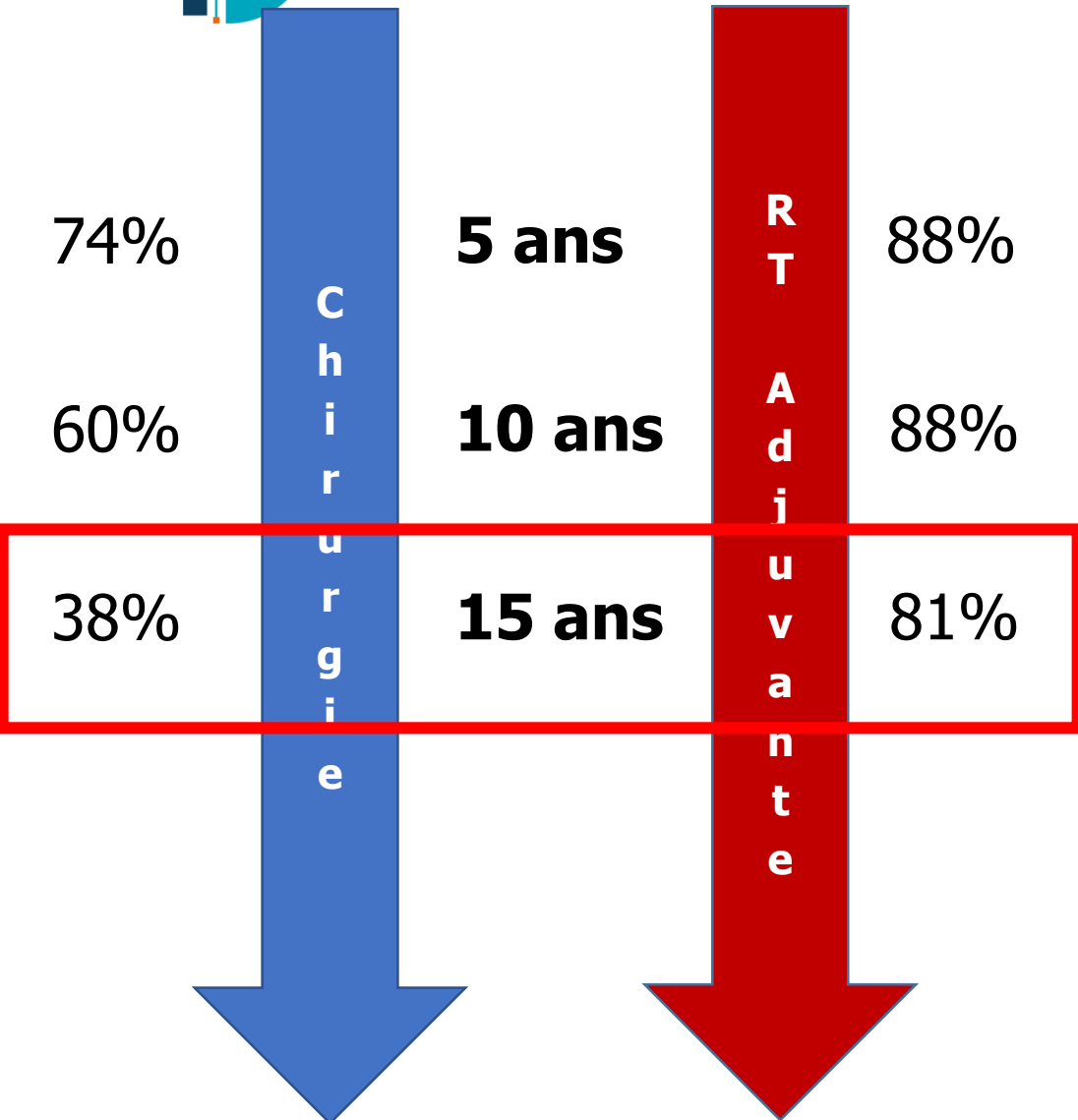

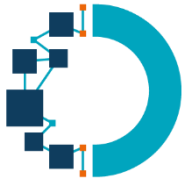

Adénomes Hypophysaires Non Fonctionnels

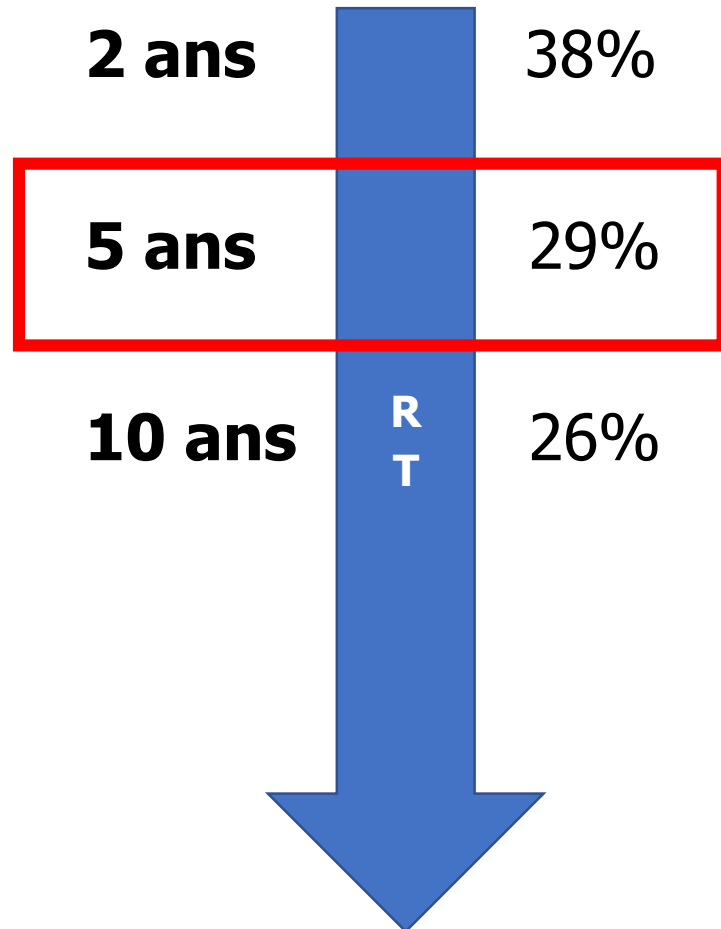

Survie sans radiothérapie après seconde chirurgie (N=50)

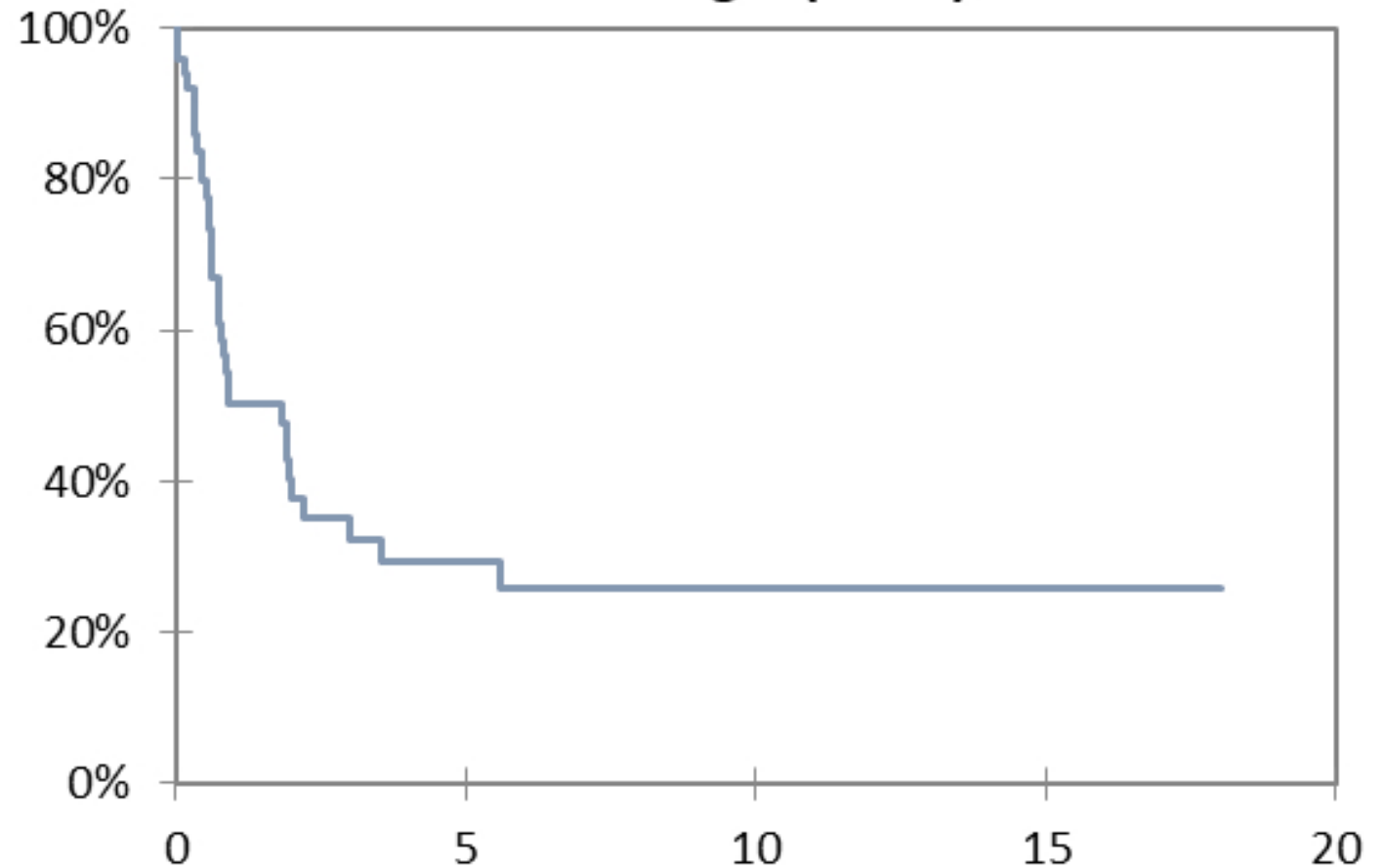



Adénomes Hypophysaires Non Fonctionnels

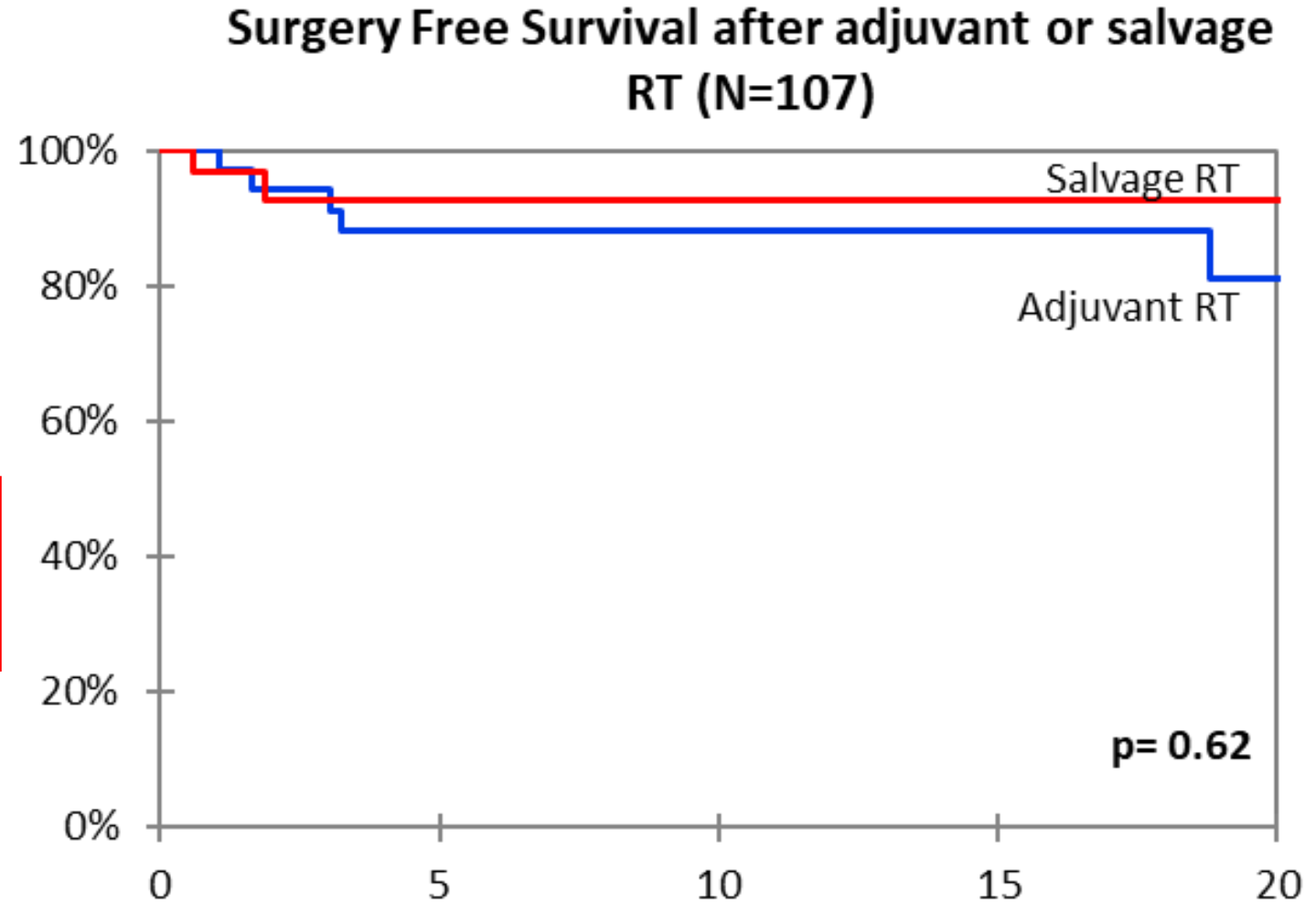
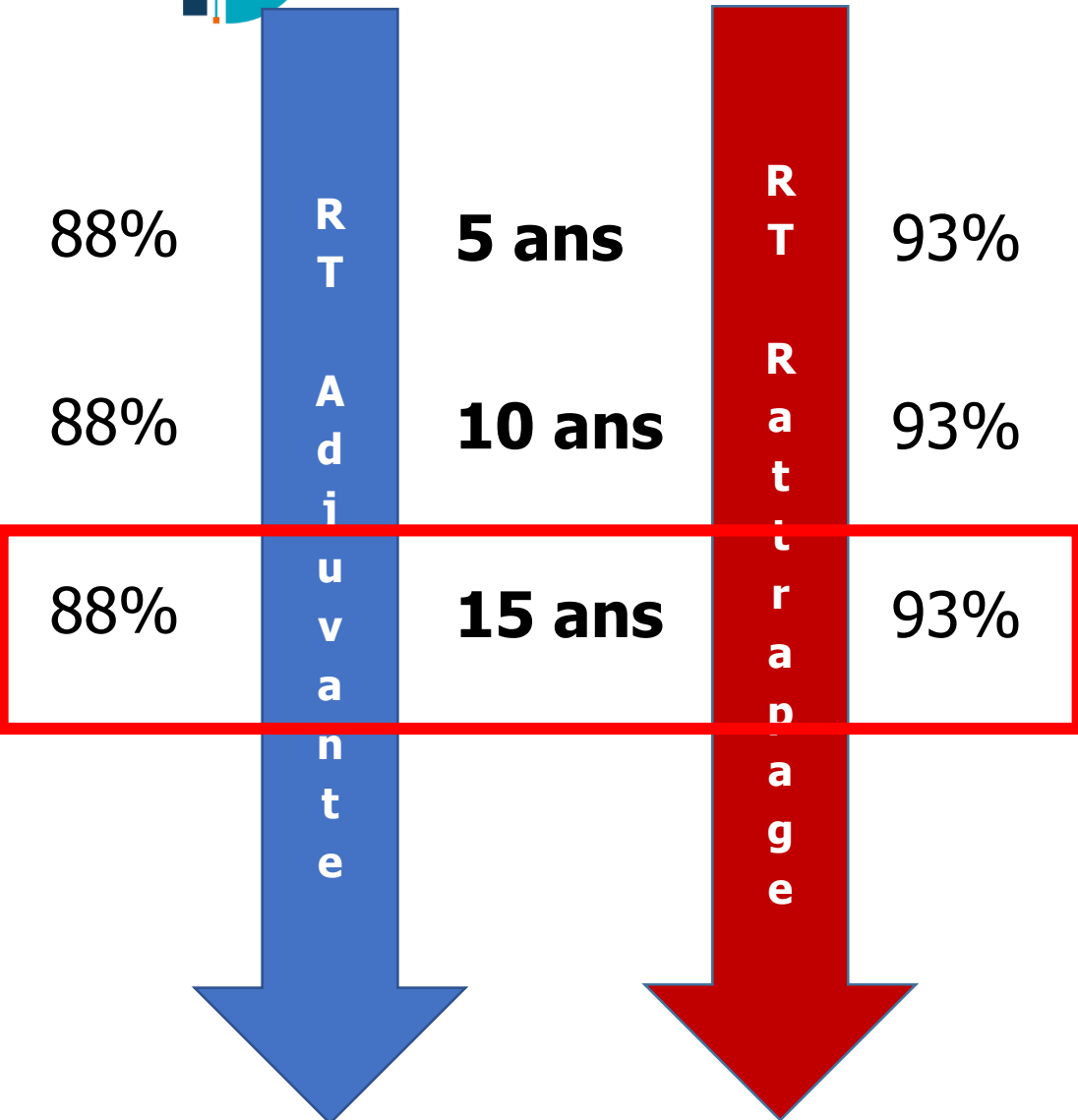



Adénomes Hypophysaires Non Fonctionnels

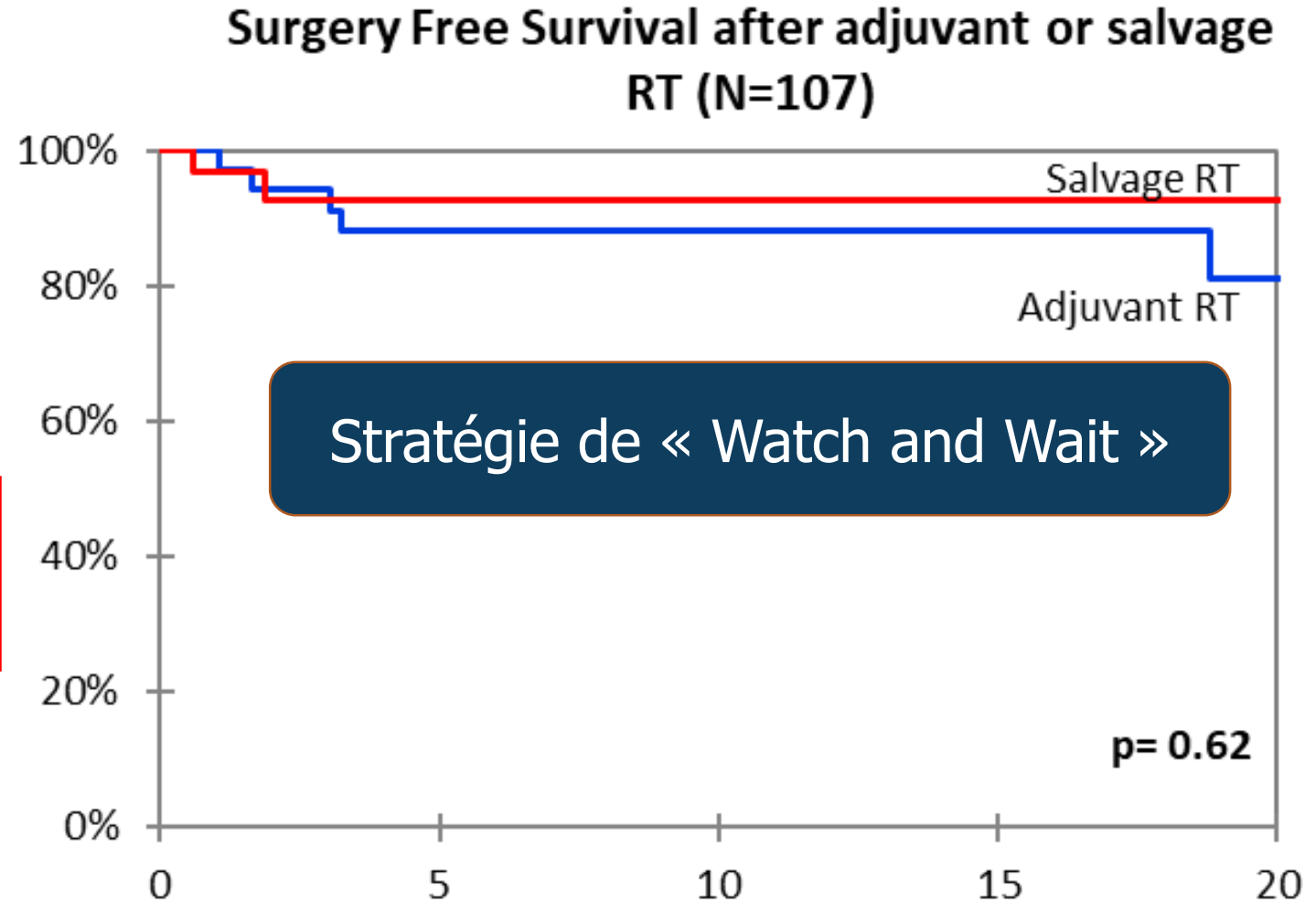
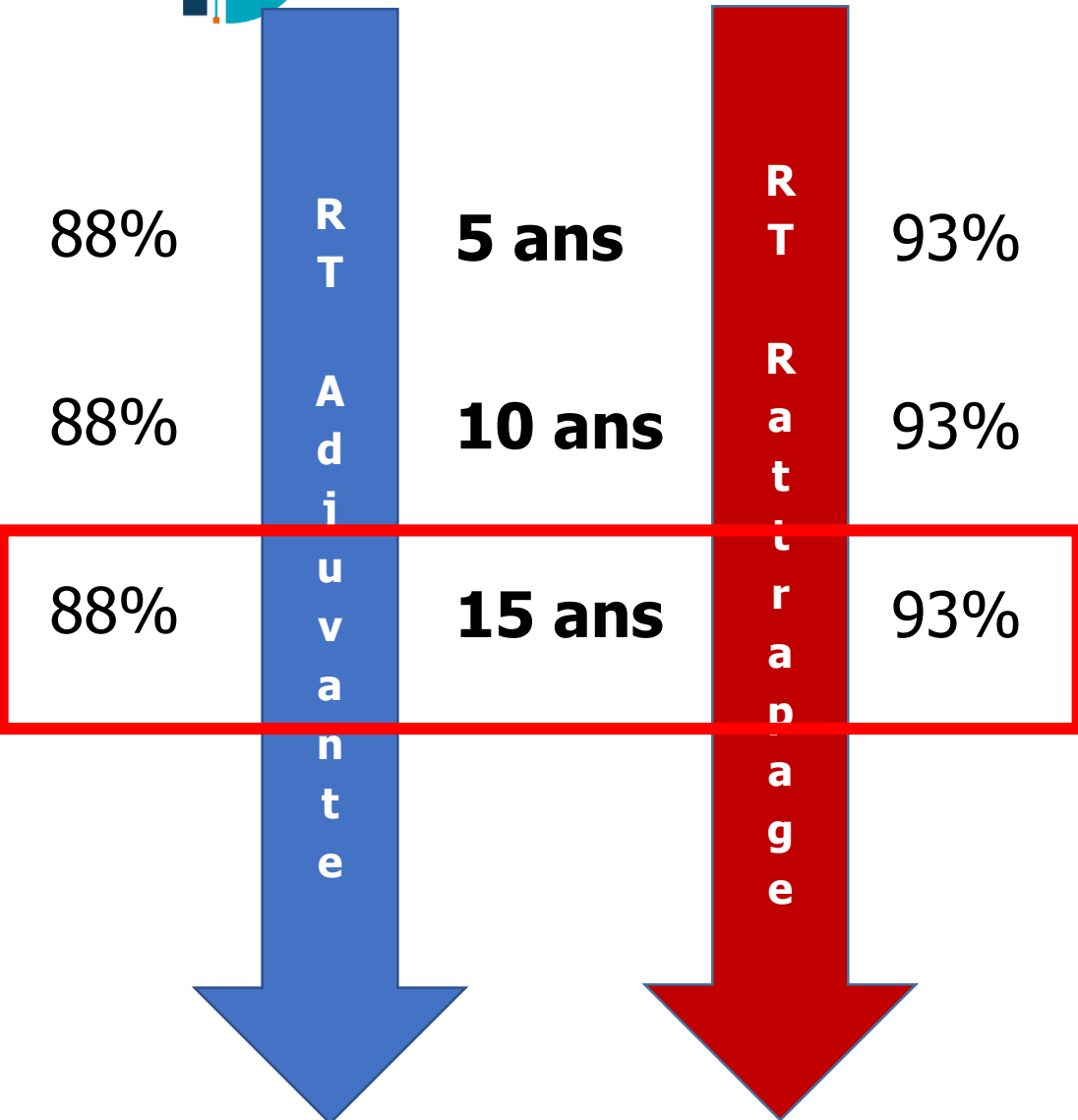

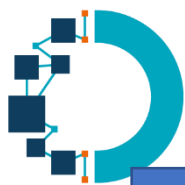

Adénomes Hypophysaires Non Fonctionnels

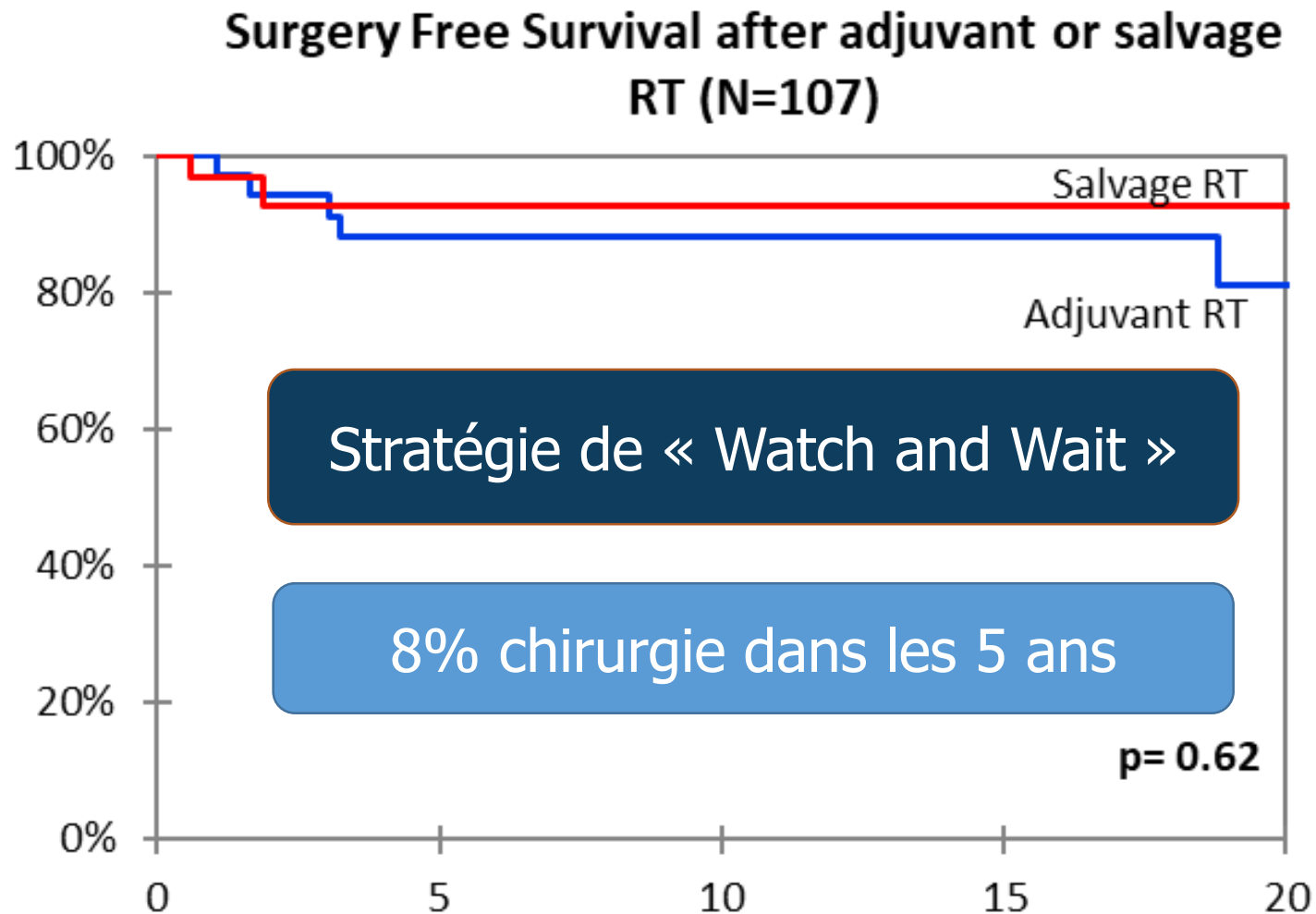
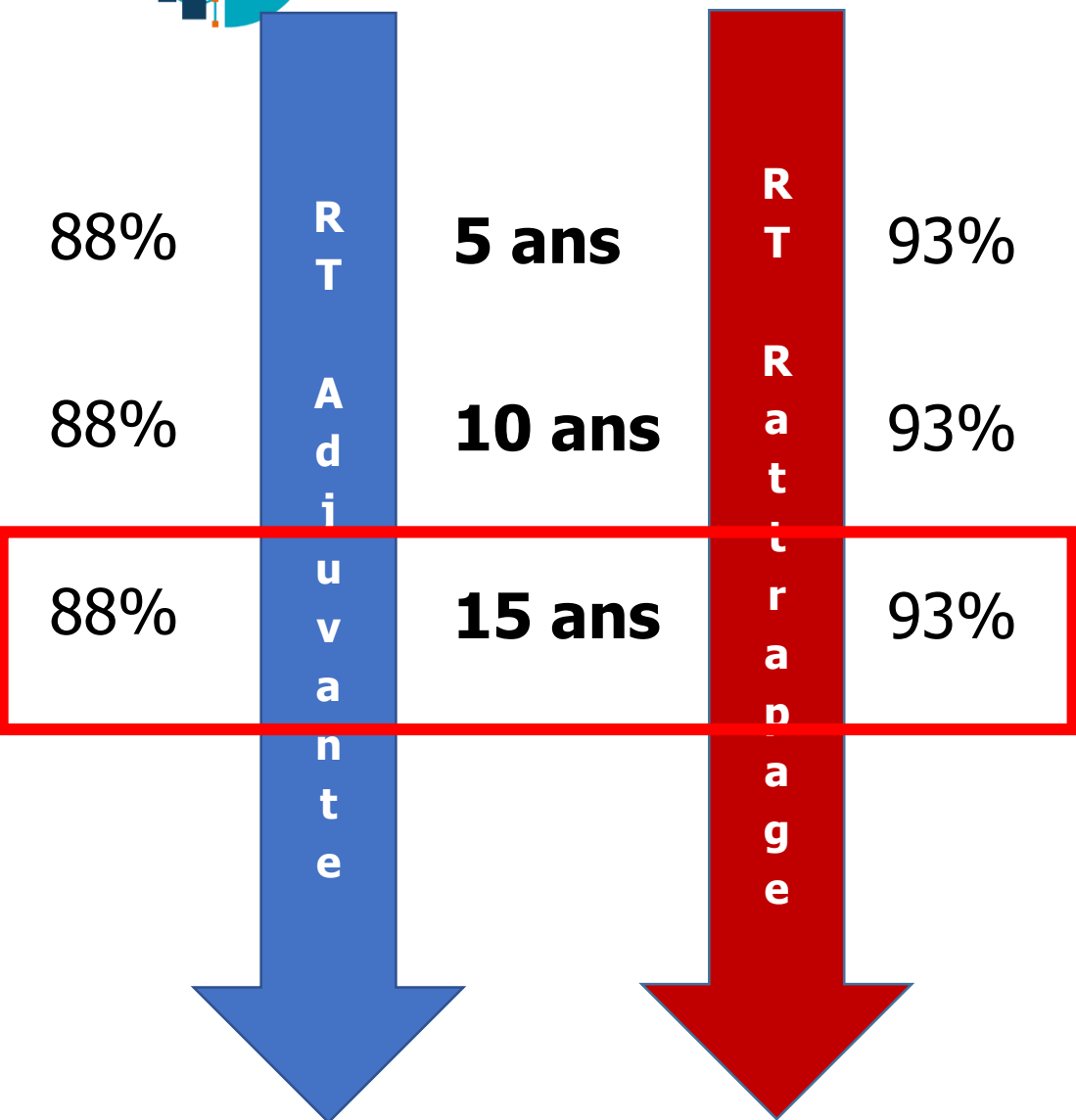

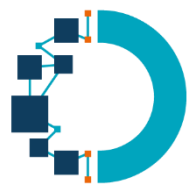

A retenir



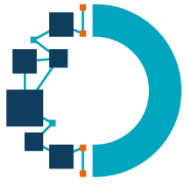

A retenir

1^{ère} chirurgie = indispensable

Fort risque de récurrence

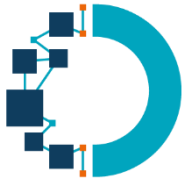

A retenir

1^{ère} chirurgie = indispensable

Fort risque de récurrence

2^{nde} chirurgie

3/4 RT dans les 5 ans

RT rattrapage = RT adjuvante

8% chirurgie dans les 5 ans

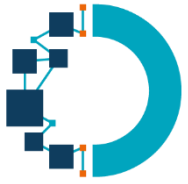

A retenir

1^{ère} chirurgie = indispensable

Fort risque de récurrence

2^{nde} chirurgie

3/4 RT dans les 5 ans

RT rattrapage = RT adjuvante

8% chirurgie dans les 5 ans

Stratégie de « Watch and Wait »



Merci pour votre attention

